

Brand New 1000 GPD Reverse Osmosis Unit

OPERATING AND MAINTENANCE MANUAL



Puritech 1000GPD systems are part of a family of reverse osmosis units specifically designed for operation with fresh and brackish feed waters having TDS values below 1,500ppm. Customers can access these Models with permeate output of 125 liters/hr as shown in the specifications.

The reverse osmosis systems have been widely used for commercial purposes such as treatment of wastewater, desalination, minerals reclamation, and purification of water. If you have been searching for the best and efficient Industrial RO system, then you have landed at the right place. At Puritech, we provide the best quality of RO water units that can meet your needs, expectations, and budget.

We provide the highest standard and compact commercial reverse osmosis system at an affordable pricing range. All our RO systems are highly durable and we guarantee that they can be last for many years with proper care and maintenance.

Table of Contents

- 1. Introduction**
- 2. Safety Precautions**
 - 2.1. General Safety Precautions
 - 2.2. Safety Headings
- 3. Labelling**
- 4. General Plant Description**
 - 4.1. Purpose
 - 4.2. Principle Process
 - 4.3. Process Flow
- 5. Process Description**
 - 5.1. Pre-Filtration
 - 5.2. Reverse Osmosis (RO)
- 6. Technical Data**
 - 6.1. Equipment Details
 - 6.2. Operating Parameters
- 7. System Requirements**
 - 7.1. Plumbing
 - 7.2. Electrical
- 8. Operating Procedures**
 - 8.1. System Overview
 - 8.2. Full System Start Up
 - 8.3. Full System Shut Down
- 9. Maintenance Information**
 - 9.1. Plant Operator Log Sheet
 - 9.2. Maintenance Tasks
 - 9.3. Cartridge Filter Element Replacement Procedure
 - 9.4. RO Element Replacement Sequence.
 - 9.5. Recommended Spares List
 - 9.6. Troubleshooting Guide

Benefits

- Specialized Micro-Computer Controller
- Fully Equipped and Customizable
- Super-Quiet BWI 1-6 Horizontal Multistage Pump
- Low Energy Consumption
- High Flow Low-Energy Membrane
- Low Maintenance
- Compact Space Saving Design

Standard Features

- RO micro-computer controller with permeate TDS readout
- 300PSI stainless steel membrane housing+PE end caps
- Shimge BWI 1-6 multistage pump for 1000GPD
- 5 micron sediment pre-filter x 1
- Puritech rotameter for permeate and concentrate stream
- Puritech pressure gauges for prefilter feed and RO feed
- High pressure switch
- Electro-plated SS304 skid frame

Available Options

- RO membranes available with brands of Filmtec, Hydranautics, Vontron and Toray
- FRP membrane vessel
- Grundfos multistage pump
- Shimge multistage pump
- Concentrate recycling flow meter
- Provision for CIP

1. Introduction

This operating and maintenance manual outlines a general overview, operation, maintenance and troubleshooting details vital to the sustained performance and understanding of your system.

NOTE: Before operating or servicing this system, this operating and maintenance manual must be read and fully understood. Keep it and other associated information regarding this system safe for future use.

2. Safety Precautions

2.1. General Safety Precautions

The system should be operated and maintained by trained personnel. Personnel must comply with this manual as well as the safety measures listed by their own employer. Water Purification Solutions cannot be held liable for any damages, injury or even death that may result from use of this system.

2.2. Safety Headings

The safety section of this manual outlines various safety headings throughout the manuals' text and are identified and defined as below:

- NOTE:** Indicates statements that provide further information and clarification.
- CAUTION:** Indicated statements that are used to identify conditions or practices that could result in equipment or property damage.
- WARNING:** Indicates statements that are used to identify conditions or practices that could result in injury or loss of life. Failure to follow these warnings could result in serious injury or even death.

3. Labelling

Do not remove any labelling of this system. These labels are used to warn against potential hazards as well as identify components

4. General Plant Description

4.1. Purpose

To reduce dissolved salt content of raw water for later use.

4.2. Principle Process

Reverse Osmosis (RO) is a form of high pressure hyper filtration where dissolved solids are removed from the supply stream to produce treated water (permeate) and waste water (concentrate). This is a continuous process running at a fixed flow rate.

4.3. Process Flow

Water is fed from a saline supply with minimal suspended matter, i.e. Pre-treated water, to the filter cartridge before being pumped through the reverse osmosis (RO) stage of the system where the dissolved salt content is reduced. The treated water (permeate) is fed into a holding tank and the concentrate to drain.

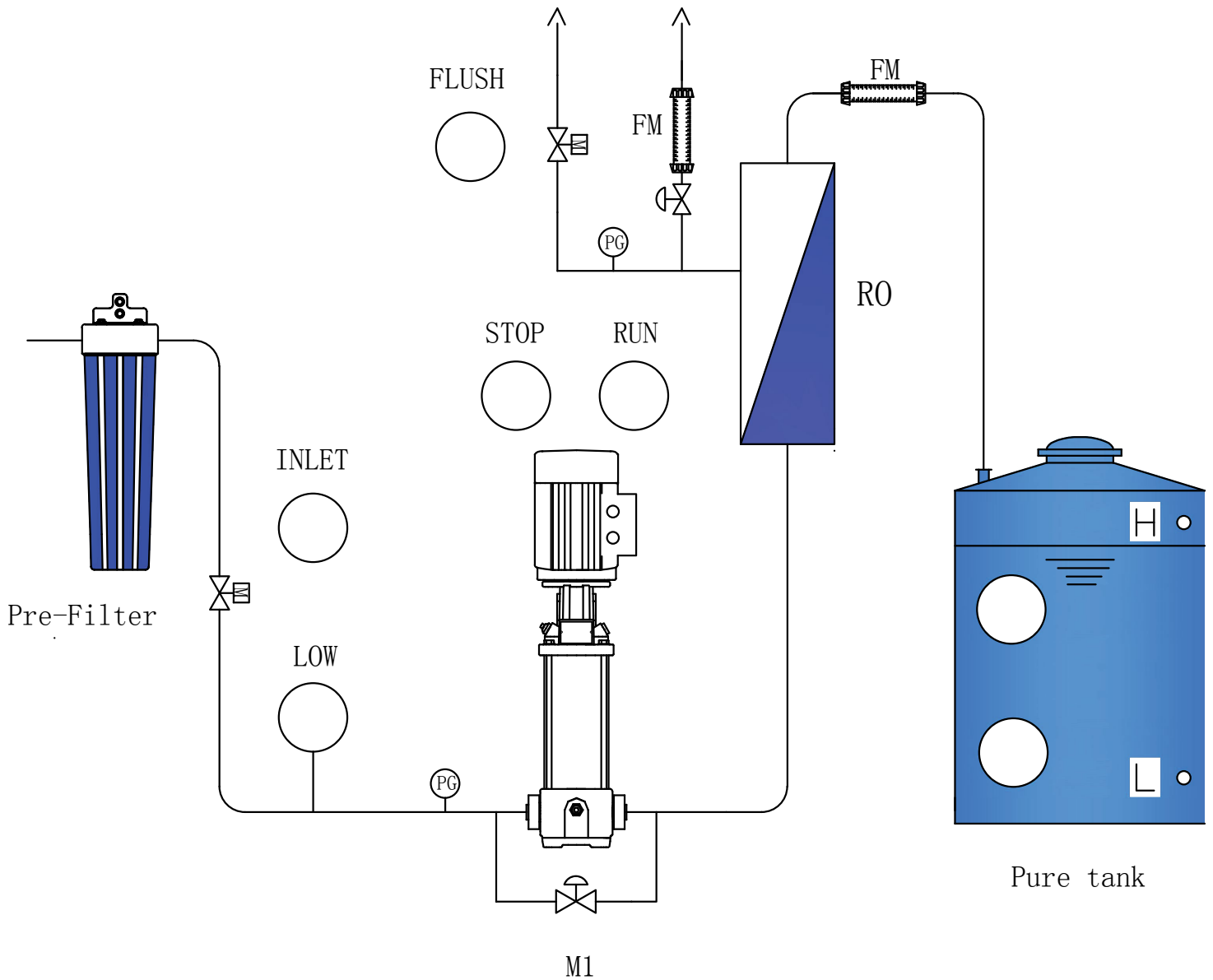

5. Process Description

5.1. Pre-Filtration

Raw water is fed through a pressurised line into the water treatment system.

The filtration stage of the system consists of a cartridge filter in which suspended matter larger than 5 micron is removed.

A solenoid valve is used to shut off the supply line when the holding tank has reached its top level or when the system is turned off.

5.2. Reverse Osmosis (RO)

Pre-filtered water is fed to the RO system by means of the horizontal centrifugal pump. The pump is controlled by the following parameters, namely:

- Product tank high level, indicated by a float level switch
- Raw supply tank low level, indicated by a float level switch.
- Low pressure condition, indicated by the pressure switch
- Timer unit contact.

The RO system generates two streams of water, a purified stream (permeate) is directed to the product tank while the concentrated stream is directed to the drain. A ball valve on the concentrate line allows for manual flushing of the RO system. Pressure indicators are fitted at strategic points to illustrate the systems operating pressure. Flow rate through the system can be monitored by the inline rotameters on both the permeate and concentrate lines.

En route to the product tank, permeate passes a conductivity probe, which reads conductivity of the product water

6. Technical Data

6.1. Equipmenty Details

Reverse Osmosis Pump	Tag	: P-1
	Qty	: 1
	Model	: Shimge BWI 1-6 multistage pump
	Duty	: 2000L /hr @10 bar
	Power	: 1.5 kW
Cartridge Filter	Tag	: CF-1
	Qty	: 1
	Material	: Polypropylene
	Dimensions	: Ø 4.5" x 10" L
	Elements	: 5 µm, MeltBlown
Solenoid Valve	Tag	: SV-1
	Qty	: 1
	Model	: ZS1DF13N4D16
	Actuated	: Electrically, DC24V
	Pipe	: ½" Orifice, 16mm
Reverse Osmosis Vessel	Tag	: RO-1
	Qty	: 1
	Model	: 2.5", 1 Element, 300 PSI
	Port Position	: End Port
	Element	: ULP21-4040 (Vontron)
Rotameter	Tag	: FLM-1
	Qty	: 1
	Range	: 100-1000l/hr
	Thread	: ½" F BSP

Rotameter	Tag	FLM-2
	Qty	1
	Range	16-160 l/hr
	Thread	½" F BSP
Pressure Switch	Tag	: PS-01
	Qty	: 1
	Model	: MPCo6
	Range	: -0.5-6bar
Pressure Indicator	Tag	: PI-01
	Qty	: 1
	Model	: 63mm, ¼" BSP, Bottom Entry
	Range	: 0-10 bar
Pressure Indicator	Tag	: PI-02
	Qty	: 1
	Model	: 63mm, ¼" BSP, Rear Entry
	Range	: 0-10 bar
Conductivity Meter	Tag	: Conductivity Meter
	Qty	: 1
	Model	: CM-230
	Range	: 0-199.9µS/cm

6.2. Operating Parameters

Cartridge Filtration

Service Flow Rate	: 0.625m ³ /hr
Max Operating Pressure	: 6 bar
Element	: 5 Micron (Ø4.5" x 10" L)
Replacement Intervals	: When required (Minimum once a month)

Reverse Osmosis

Service Flow Rate	: 0.125 m ³ /hr (permeate)
Max Operating Pressure	: 10 bar
Element	: ULP21-4040 (Vontron) x1
Replacement intervals	: When required

7. System Requirements

7.1. Plumbing

System connections are as follows:

- From raw supply to system inlet : 1" PVC
- From permeate outlet to product tank : ½" PVC
- From concentrate outlet to drain : ½" PVC

NOTE: Ensure the diameter of pipeline can supply adequate flow with minimal head loss relative to pipe length.

NOTE: All municipal drain connections should not be connected together in a closed drain with any backpressure. i.e. drainage must be free flowing.

NOTE: The Brine from the RO has a high mineral content and should be delivered to drain or evaporation dam.

NOTE: We recommend that a qualified plumber installs the plumbing lines to and from the system

WARNING: The plumbing of this system is constantly under pressure during operation. Incorrect installation or operation of the system could result in serious injury or even death.

7.2. Electrical

The electrical supply required for the plant is 220V, 5A, 50Hz, single phase with Neutral and Earth.

NOTE: We recommend that a qualified electrician installs the electrical supply to the system.

WARNING: To reduce the risk of electrical shock, the incoming electrical supply must include a protective earth connection. Electrical shock can result in serious injury or even death. Ensure the system is isolated from the supply before any electrical work commences.

WARNING: Incorrect installation of the electrical supply can result in serious damage to the equipment but can also result in serious injury or even death

8. Operating Procedures

8.1. System Overview

TDS Monitor

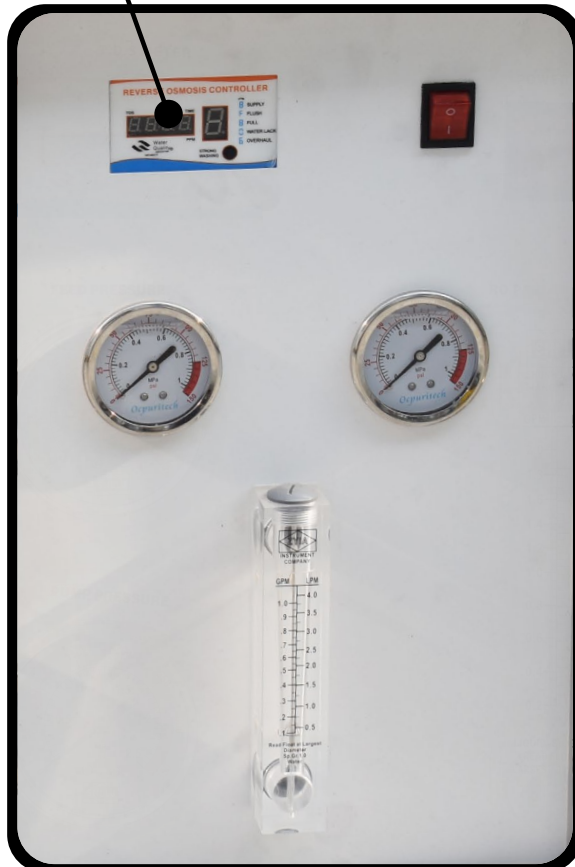

A: Feed water inlet connection, from the 20" blue filter .

Start running machine procedure;

1. When the system arrival site ,take out the package ;

The first step: connect local water pipe and local power ;

1) Water pipe: 3 connection :

B: Waste water connection, from the pipe with the red wheel regulate valve; please refer the below picture;

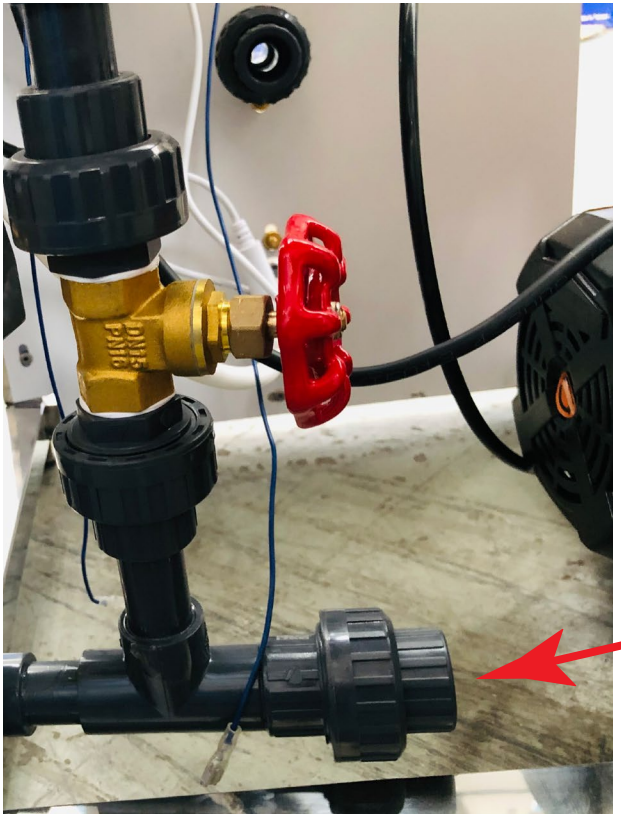

C : pure water connection ,from the pipe connect with the flow meter; storage water to the water tank ;please refer to the below picture;



2) After done 3 water pipe connection , the next step is power ;
It is simple , only need to Put the plug in the socket ; please pay attention , the voltage is 220V,50HZ,1P;

2. After done the water pipe connection and power connect. Make sure feed water have enough water coming. The next step ,install PP filter and RO membrane ;

1) PP filter ; before taking new one 20" PP filter cartridge, should use the spanner to open the cap of the 20" blue filter housing, remove the Transparent plastic bag packaging of the PP filter cartridge, put inside the housing. No direction limit.

Please pay attention , the PP filter cartridge need to exchange every 3 months.

2),membrane installation: Take the side with the seal as the (feed) inlet water direction; Please ready the Lubricating oil first ;

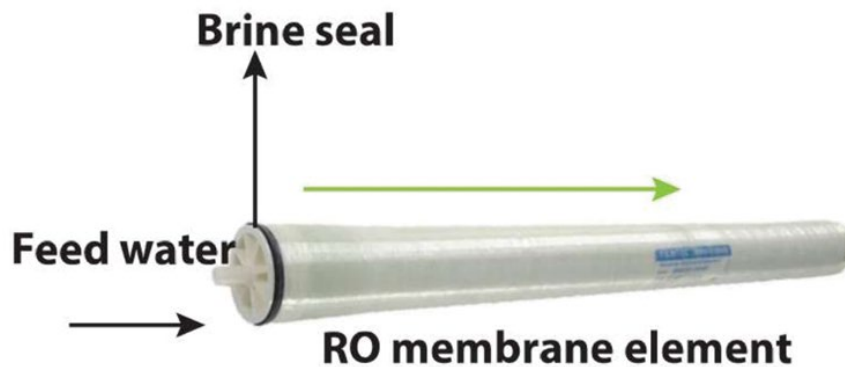

3. When Done, The next step, running the system, only need to press the power ; like the below picture :

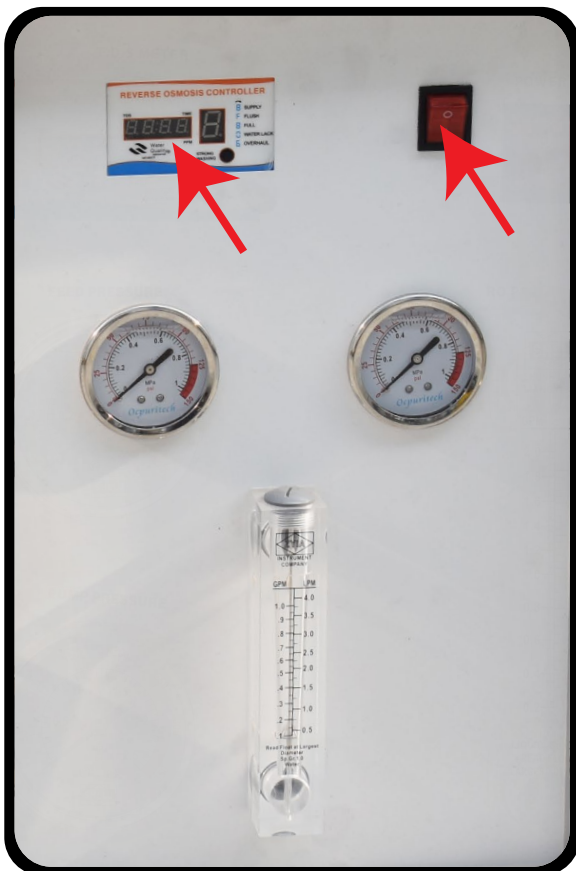

When the power on , here the 8 with flashing by cycle; it means the system running properly; the controller user manual, please check the attached file.

There are 2 troubleshoot please pay attention 1),when the flashing showing 0, it means the water lack or low pressure alarm,please need to check 2point ,

A: Check the pump inlet coming water or the feed water tank , to see if no water ; if yes, please make sure there is constantly water coming , or full level of the feed water tank;

B: Adjust the pressure switch , to make it more low pressure , please check the below detail ;

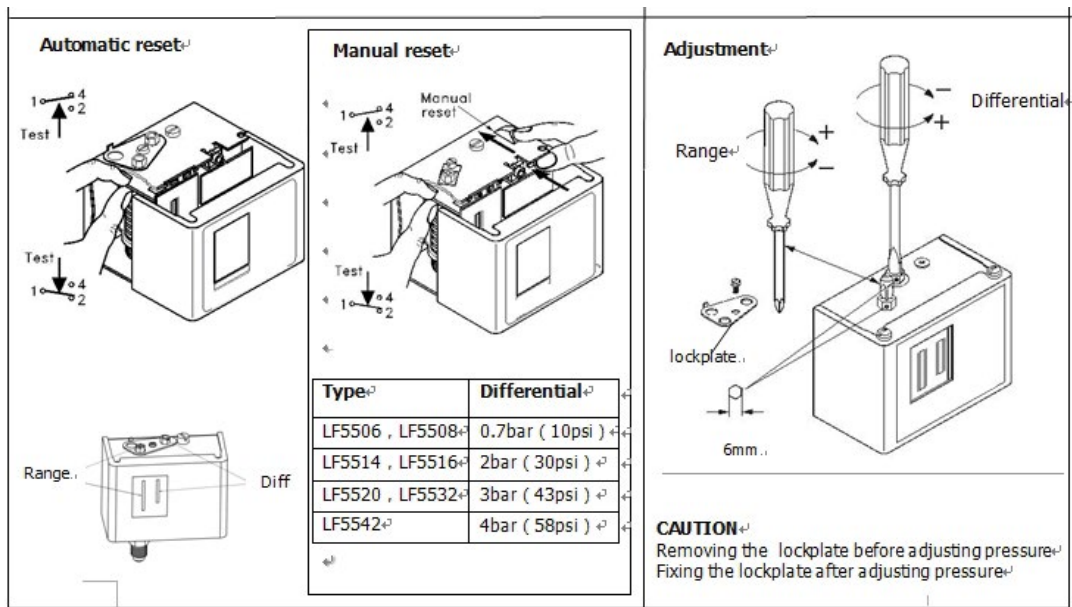

2), when the flashing show 6; it means overload ,pump overload, need to exchange the fuse from the pump starter.

4. The system main controller, please check carefully about the ;

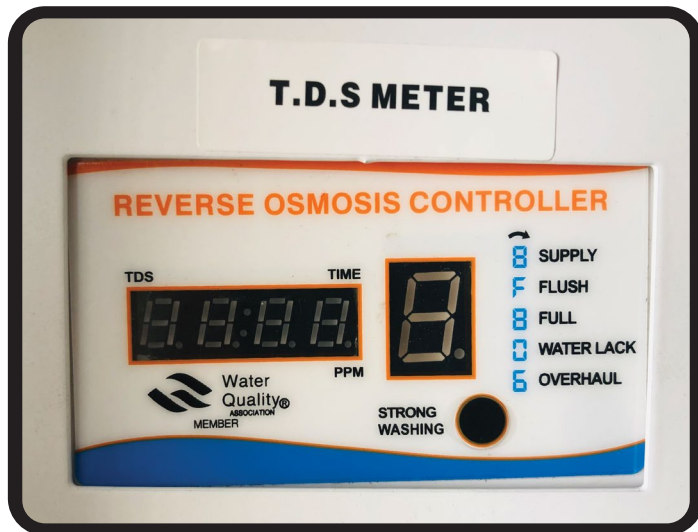

Display Description

Display Status	Working Status
F	The controller is in the initial state while controlling the machine to enter the flushing program
8	The machine enters the water production process, and the cycle displays 8
8	Full water level program status, display fixed on 8
0	The source water pressure is too low or no source water , cuts off the power and alarms 10 to inform the user
6	water leakage is detected, the machine stops working, and the maintenance is displayed.

Control Button

Manual Flush: This button may be pressed to initiate a membrane flush cycle while the system is in normal operation. After 60 seconds of membrane flushing, normal system operation will resume.

Pre-programmed Control Process

1. Power-on full display, accompanied by "BI" 1 sound, flush for 30 seconds (low pressure closed), 4 pcs of "8" words display countdown; low pressure switch disconnected, it shows source water storage. The source water shortage recovery delay is judge for 2 seconds, and then flush for 30 seconds.
2. After the flushing is completed, judge whether the high pressure switch is closed. If the high pressure switch is closed, it will enter the water making state, indicating that the accumulated operation is 8 words, and the delay is 5 seconds to display the TDS value (4 zeros are displayed during 5 seconds). When the water is produced, the TDS value shows the ppm value of the purified water in real time. When the high-pressure switch is turned off (after the pure water tank is full), the water is turned off by 0.5 second, and the TDS shows the value of the memory water.
3. The high pressure switch is closed again, and the water production is automatically entered after a delay of 3 seconds. At this time, the TDS is delayed by 5 seconds to display the value (before the period is maintained).

4. Accumulated water for 2 hours, automatic flushing once, the time is 30 seconds; when there is leakage, the detector detects the water leakage, the control box immediately closes the inlet valve to stop the machine, and alarm.
5. The TDS probe is shorted to display E1. TDS detected more than 999ppm, both showed 999.

The wire connection

1. Pressure switch Yellow Color
2. Tank Level Switch Blue Color
3. Flush Solenoid Valve Red Color
4. Booster Pump Green Color
5. Inlet Solenoid Valve Black Color
6. Power Pink & White 220V 50/60Hz



Solenoid Valve (SV-1)

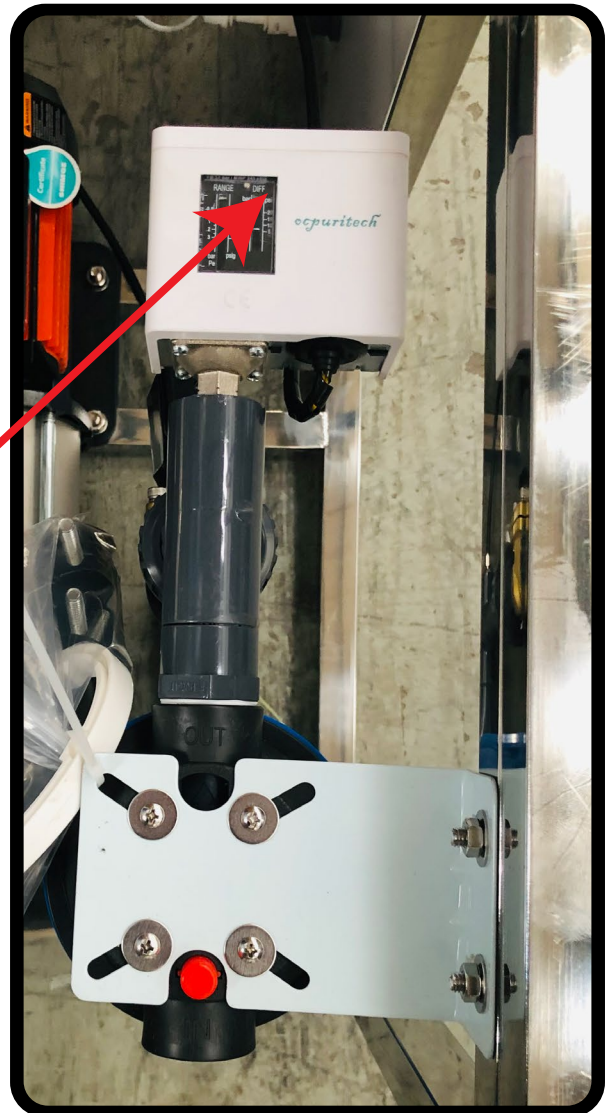

Pressure Switch (PI-01)

8.2. Full System Startup

A full system start up is performed when the system has been shut down for an extended period of time or after commissioning.

- Ensure all supply valves from the raw supply are open.
- Attach a plug to the system and plug into wall socket. Flip the switch to the "ON" position at the wall.

NOTE: The pump will only start if the level switches are in the correct orientation, i.e. product tank is empty and there is sufficient supply pressure

- Regulate MV-01 (just after pump) to allow for a slow flow.
- Regulate the control valve-(CV-1) on the concentrate line and the manual valve (MV-2) on the permeate line to allow a concentrate flow of around 500l/hr and a permeate flow of around 125l/hr. Confirm with rotameters (FLM-1 &2).
- Confirm RO pressure (PI-01 & 02) and flows (FLM-1 & 2). Ensure the correct flow and pressures as noted at last plant shut down, operating parameters (Please refer to 6.2 Operating Parameters).

8.3. Full System Shut Down

A full system shut down is performed if the plant is to be shut down for a period of three weeks or longer.

- Record all system operating parameters.
- Flip the switch to the "OFF" position at the wall.
- Ensure the following valve sequence is met:
MV-1-Closed
MV-2-Closed
CV-1-Closed

9. Maintenance Information

9.1. Plant Operator Log Sheet

The water treatment system has been designed to the function with minimum input from the operator.

However, it is strongly recommended that a daily log of important system parameters and activities is kept.

These records are of utmost importance for gauging the systems long term efficiency as well as being a vital key in speeding up the troubleshooting, in the event of failure.

Review the log sheet on a regular basis for changes in operating parameters, water qualities etc. Regular monitoring of the system can bring imminent failures to light before stoppages result. Any abnormal conditions should be attended to or reported immediately.

Changes in raw water quality must be monitored on a regular basis to maintain acceptable treated water quality. It may be necessary to adjust operating flows and pressures.

9.2. Maintenance Tasks

Daily

- Maintain the system in a clean and tidy condition.
- Inspect the system for any leaks. If any, seal/repair them accordingly.
- Monitor the system for any abnormal conditions such as excessive noise, vibration or heat. If any present it should be reported and attended to immediately.
- Check and adjust flow rates as per operating parameters.
- Check operating parameters and complete Daily Operator Checklist.

Monthly

- Replace cartridge filter element.

1-5 Years

- Replace Reverse Osmosis membrane, if required.

9.3. Cartridge Filter-Element Replacement Procedure

The cartridge filter (CF-1) has a 5 micron nominal pore size. This element will be required to be replaced periodically as the filter blinds with filtered matter. The filter element should be replaced every four weeks.

9.4. RO Element Replacement Sequence

- Turn off the system by flipping the switch to the "OFF" position at the wall.
- Ensure that the supply water is isolated from the cartridge filter.
- Release any trapped pressure by pressing the air release valve on top of the housing before attempting to open.
- Use the housing spanner supplied to open the housing by turning the spanner in a clockwise manner. Once loosen turn the rest by hand.
- Dispose of the used element. Replace with a new element, ensuring that the elements bottom port is securely placed in the bottom port of the housing.
- Secure the housing by turning in an anti-Clockwise manner.
- Reconnect the filter to the raw water supply.
- Turn on the system by flipping the switch to the "ON" position at the wall.

NOTE: Bleed off any trapped air by pressing the air release valve on top of the housing during start up.

9.5. Recommended Spares List

The following spares holding are recommended for minimizing downtime of the plant in the event of failure as well as during the maintenance period.

Description	Qty
Shimge BWI 1-6 multistage pump	1
RO Membrane-ULP21-4040 (Vontron)	1

9.6. Troubleshooting Guide

PUMPS		
Symptom	Possible Cause	Possible Solution
RO pump, not starting/running	High water level in product tank, Float level switch activated	Confirm high level in product tank
	Power Supply	Check power supply to system Faulty relays
RO pump running but no pressure	Check water supply	Bleed pump
Switched to auto but pump not switching off on timer	Timer disconnected	Press timer into socket, check wire connection.
	Timer unit malfunction	Repair or replace timer
Switched to Manual or Auto but pump does not start	Electrical supply fault	Check supply state
	Low water pressure	Increase feed pressure or decrease flow to RO
Pump gets extremely noisy during operation	Insufficient feed flow	Check supply pressure, check pipes and pre-filter for blockages.

Misc. System		
Symptom	Possible Cause	Possible Solution
Switched to Manual or Auto but inlet valve does not open	Valve disconnected	Check connection
	Valve malfunction	Repair or replace valve
System stops due to low pressure	Insufficient feed pressure	Check supply pressure
	Pre-filter cartridge blocked	Clean or replace pre-filter

REVERSE OSMOSIS		
Symptom	Possible Cause	Possible Solution
RO, Low operating pressure (PI-02)	Perforated Membrane	Flush and clean the membrane element
	Power supply	Confirm voltage
	Pump not operating correctly	See the pump instructions
RO, Low permeate flow rate (FLM-2)	Low operating pressure	See possible causes for low pressure above
	Dirty or fouled membrane elements	Clean the membrane elements
	Membrane elements installed backwards or damaged concentrate seal	Install membrane elements in the direction of fluid flow. Clean the machine immediately.
	Flow meter inaccurate	Check the flow rate manually with a stop watch and calibrated container
RO, Low concentrate flow rate, normal or higher than normal pressure	Concentrate valve plugged	Remove the concentrate valve and /or disassemble the plumbing. Clean the valve
	Flow meter inaccurate	Check the flow rate manually with a stop watch and calibrated container
RO, Low concentrate flow rate, normal or higher than normal pressure	Dirty concentrate valve	Disassemble and clean plumbing to the valve
	Inaccurate pressure gauge	Recalibrate the gauge as required
RO, High operating pressure	Restricted or reduced flow rate	See the possible causes for low permeate rate above
		Refer to the control values on daily operator sheet (9.1 Plant Operator log sheet).
	Restricted flow after pump outlet	Check for blockage of the concentrate flow at the inlets and outlets of the membrane element housings
RO, Excessive pressure drop [exceeding max ΔP] (high primary pressure low final pressure)	Telescoped membrane element covering membrane element housing outlet port	Ensure that the anti-telescoping device is located properly on the membrane element
	Severely fouled or dirty membrane elements	Flush the system, then clean it with detergent.
	Dirty or fouled membrane elements	Flush and clean the membrane elements
RO, High permeate conductivity	O-ring seal broken or damaged	Replace the O-ring, check the sealing surfaces on the O-ring groove interconnectors and end caps. Replaced damaged parts.
	Change in incoming water quality	Open the concentrate valve and flush. Test the water for pH, Hardness, TDS and iron content. A water analysis should be sent to WPS for review.

VONTRON INDUSTRIAL MEMBRANE ELEMENTS

ULP SERIES RO MEMBRANE ELEMENTS

Brief Introduction

ULP series of ultra-low pressure aromatic polyamide compound membrane elements newly developed by Vontron Technology Co. can operate under ultra low pressure to reach as high a permeate flow and salt rejection as regular low-pressure membrane elements and are applicable to the desalination of surface water and underground water. They operate at approximately 2 thirds of the operating pressure of regular low-pressure composite membranes and can achieve a salt rejection rate of up to 99.5%, which can decrease the investment costs for such relevant components as pumps, piping, and vessels, etc. including the operating cost for the RO system, thus increasing the economic efficiency. Being suitable for the desalting of water sources with salt concentrations lower than 2,000 ppm, such as surface water, underground water etc., ULP series of membrane elements are mainly used for applications such as pure water production, boiler water replenishment, foodstuff processing, and pharmaceutical production.

Vontron ULP21-4021 Reverse Osmosis Membrane

Vontron ULP21-4021 ultra low pressure membrane delivers high permeate flows and salt rejection at lower raw water pressures, compared to regular low-pressure membrane elements. The high salt rejection and low working pressure result in up to 30% lower energy consumption compared to standard elements.

Vontron ULP 4021 series of low pressure membrane element are based on a 10.3 bar (150 PSI) test pressure.

Product Specifications:

- Salt Rejection: 99%*
- Permeate Flow: 950 gpd (3.6 m³/day)*
- Membrane Area: 36 ft².
- Diameter / Length: 4 inch / 21 inch.

*Test conditions: 1500 mg/l NaCl, 10.3 bar (150 psi), 25 °C (77 °F), pH 7.5, recovery rate 8%.

*Pre-treatment must be used to protect the membrane (softener, antiscalant dosing pump, sand filter, carbon filter, 5 mic cartridge filter ...etc).

Vontron ULP 4021 membrane is suitable for water purification applications of water sources with salt concentration lower than 2000 ppm, such as surface water, underground water, tap water and municipal water.

Commercial Application:

- Drinking water.
- Softened water for homes, hotels, commercial laundries and car wash.
- Spot free rinse, used for window cleaning and solar panel cleaning
- Pure water for pharmaceuticals, laboratories, Hemodialysis and electronics
- Sterilisers and autoclaves.
- Chemical industry.
- Aquarium water treatment.
- Boiler and cooling towers make-up water.
- Pure water, boiler water replenishment, foodstuff processing, and pharmaceutical production..

Compatible with reverse osmosis membrane types:*

Filmtec TW30-4021 / Filmtec XLE-4021 / GE Desal AG4021 / Hydranautics ESPA4-4021 / Toray CSM RE4021-BE.

*Check the data sheet for each membrane.

Operation Conditions:

- Max. working pressure: 600 psi (4.14MPa)
- Max. Feed water flow: 16 gpm (3.6 m³/h)
- Max. Temperature of Feed water: 45°C
- Max. Feed water SDI₁₅: 5.
- Max. Feed Water Total Hardness: 10 ppm (softener or antiscalant should be used).
- pH Range of Feed water during Continuous Operation: 3~10
- pH Range of Feed Water during Chemical Cleaning: 2~12
- Residual chlorine Concentration of feed water <0.1ppm Max.
- Pressure drop of single membrane element: 15psi (0.1MPa)

Pressure Switch

The Pressure Switch is used for regulating, monitoring of pressure gauges and have a wide range of industrial applications.

Features

- Ultra short bounce time
- Compact dimensions
- Shock- and impact-resistant

Specifications

- Operating Differential Pressure: 7.00 bars
- Operating Pressure Range: -0.2 bars
- Operating Vacuum Pressure: 7.00 bars
- Operation Mode: OFF-NONE-ON
- Outlet Operating Pressure Range: -0.2 to 7 bars
- Size: 12 x 6 x 6
- Switch Type: Pressure Switch
- Upper Temperature Rating: 40.00 degrees_celsius

Important Information

1. Any specific application must be limited within the extreme operating conditions. We strongly recommend you refer to the latest edition of the technology manual and design guide prepared by Vontron Technology Co. or consult experts proficient in membrane technology. In case the customer fails to follow the operating conditions as specified in this manual, Vontron Technology Co. will assume no liability for any results.
2. The permeate flow listed in the table is the average value. The permeate flow of a single membrane element of ULP 31 series and ULP32 series is within a tolerance not exceeding $\pm 15\%$ of the nominal value, while the single membrane element of other series has a minimum permeate flow with a tolerance not exceeding 20% of nominal value.
3. All wet-type membrane elements have been strictly tested before leaving the factory, and have been treated with the solution of 1.0% sodium hydrogen sulfite (an antifreeze solution of 10% propanediol required in winter) for storage purposes, then vacuum sealed in a plastic bag and further packed in carton boxes. In order to prevent the breeding of microbes during short-time storage, transportation and system standby, we recommend you to soak the membrane elements with protective solution (prepared with RO filtered water) containing 1.0% sodium hydrogen sulfite (food grade quality).
4. Discard the RO-filtered water produced during the first one hour after system start-up.
5. During storage time and run time, it is strictly prohibited to dose any chemical that may be harmful to membrane elements. In case of any violation in using this kind of chemical, Vontron Technology Co. assumes no liability for any outcome incurred.

Points of Attention

1. All data and information provided has been obtained from long-term evaluation by Vontron Technology Co. This data and information is accurate and effective. Vontron Technology Co. assumes no liability for any consequences caused by user's failure in abiding by the conditions specified in this manual for the use or maintenance of membrane products. It is strongly recommended that the user shall strictly abide by the requirements for design, use and maintenance of products and keep relevant records.
2. Along with technical development and product review, the information contained herein will be subject to modification without prior notification. Please keep an eye on the website of Vontron Technology Co. for any product updates.

4021 Stainless Steel Membrane Housing

4 inch x 21 inch Membrane Housing is used to hold 40 inch x 21 inch Membranes for RO, NF, UF and MF.

Low Price, Durable, Easy to Install and DIY Reverse Osmosis Membrane Housing.

Specifications

- Housing Material: 304 Stainless.
- Element Size: 4" X 21"
- Max Working Pressure: 300 PSI.
- Recommended Feed Water TDS: Below 2000 ppm.
- End Cap Material: Glass Reinforced Polyimide.
- O-Ring Material: EPDM
- Feed End Port: 3/4" BSP female
- Concentrate End Port: 3/4" BSP female.
- Permeate (Product) End Port: 1/2" BSP female.
- End Closure Type: U-Clamp.

Product 360° View

